

100G QSFP28 SR1.2 Bi-Directional Transceiver

P/N: WST-QS28-SRB-MD



Features:

- 100 Gb/s aggregate data rate
- QSFP28 Bi-Directional optical transceiver
- Two independent full-duplex optical channels
- 850 nm and 910 nm dual-wavelength VCSEL Bi-Directional optical interface
- Transmission distance up to 70 m over OM3, 100 m over OM4, and 150 m over OM5 MMF
- Duplex LC optical connector
- Single +3.3 V power supply
- Maximum power consumption 4 W
- Operating case temperature: 0 to +70 °C
- RoHS compliant

Applications:

- 400G QSFP-DD SR4.2 to 4 × QSFP28 SR1.2
BIDI breakout links
- 100G SR1.2 BIDI Ethernet links
- Data center interconnects
- InfiniBand HDR

Standards:

- QSFP28 MSA compliant
- IEEE 802.3 100G Ethernet compatible
- CEI-28G-VSR Electrical Interface
- Class 1M laser product according to EN 60825-1:
2014 and 21 CFR 1040.10

Description

The WST-QS28-SRB-MD module is a 100 Gb/s QSFP28 Bi-Directional optical transceiver designed for short-reach multimode fiber transmission. It converts four host electrical data lanes into two optical lanes using 850 nm and 910 nm dual-wavelength VCSEL Bi-Directional optical interfaces, supporting transmission distances up to 70 m over OM3, 100 m over OM4, and 150 m over OM5 MMF through a duplex LC connector.

The module converts four electrical input signals into two optical output lanes and converts two optical input signals back into four electrical output lanes. It operates from a single +3.3 V power supply and supports digital diagnostic monitoring through a 2-wire serial interface.

Functional Description

This product supports 100 Gb/s bit rates in a QSFP28 Bi-Directional optical module. It converts four host electrical data lanes into two optical lanes through 850 nm and 910 nm dual-wavelength VCSEL Bi-Directional optical interfaces for transmission over 2-fiber duplex LC multimode fiber. On the receiver side, the module de-multiplexes two optical input signals and converts them into four CML-compatible electrical output lanes. Figure 1 shows the functional block diagram of this product.

The module is designed for 100G SR1.2 BIDI links and can be used as the QSFP28 breakout-side module for 400G QSFP-DD SR4.2 to 4 × QSFP28 SR1.2 BIDI applications. The module operates from a single +3.3 V power supply. VccTx and VccRx shall be applied concurrently. As defined by the QSFP28 MSA, the module provides low-speed control and monitoring pins, including ModSelL, SCL, SDA, ResetL, LPMode, ModPrsL, and IntL. The 2-wire serial interface allows the host to access the QSFP28 memory map and digital diagnostic information.

Absolute Maximum Ratings

Data Rate Specifications	Symbol	Min	Typ.	Max	Unit	Notes
Storage Temperature	TS	-40		+85	°C	
Supply Voltage	Vcc	-0.5		3.6	V	
Relative Humidity (non-condensing)	RH	0		85	%	
Operating Case Temperature	Top	0		+70	°C	
Damage Threshold	THd			5	dBm	1

Note:

- The receiver shall be able to tolerate, without damage, continuous exposure to a modulated optical input signal having this power level on one lane. The receiver does not have to operate correctly at this input power.

Recommended Operating Conditions

Parameter	Symbol	Min	Typ.	Max	Unit	Notes
Case operating Temperature	TC	0		+70	°C	
Supply Voltage	VCCT	+3.135	3.3	+3.465	V	
Data Rate Accuracy		-100		100	ppm	
Pre-FEC Bit Error Ratio				2.4×10^{-4}		
Post-FEC Bit Error Ratio				1×10^{-12}		1

Control Input Voltage High			2		V _{cc}	V	
Control Input Voltage Low			0		0.8	V	
Link Distance	OM3	D1			70	m	2
	OM4	D2			100	m	
	OM5	D3			150	m	

Notes:

1. FEC provided by host system.
2. Host-side FEC is required to support maximum transmission distance.

Electrical Characteristics (Top= 0 to 70 °C, V_{CC} = 3.135 to 3.465 Volts)

Parameter	Symbol	Min	Typ.	Max	Unit	Note
Power Consumption	PC			4	W	
Supply Current	I _{cc}			1.21	A	
Transmitter						
Overload Differential Voltage pk-pk	TP1a	900			mV	
Common Mode Voltage (V _{cm})	TP1	-350		2850	mV	1
Differential Termination Resistance Mismatch	TP1			10	%	At 1MHz
Differential Return Loss (SDD11)	TP1			See CEI- 28G VSR Equation 13-19	dB	
Common Mode to Differential conversion and Differential to Common Mode conversion (SDC11, SCD11)	TP1			See CEI- 28G-VSR Equation 13-20	dB	
Stressed Input Test	TP1a	See CEI- 28G-VSR Section 13.3.11. 2.1				
Receiver						
Differential Voltage pk-pk	TP4			900	mV	
Common Mode Voltage (V _{cm})	TP4	-350		2850	mV	1
Common Mode Noise, RMS	TP4			17.5	mV	
Differential Termination Resistance Mismatch	TP4			10	%	At 1MHz
Differential Return Loss (SDD22)	TP4			See CEI- 28G-VSR Equation 13-19	dB	
Common Mode to Differential conversion and Differential to Common Mode conversion (SDC22, SCD22)	TP4			See CEI- 28G-VSR Equation 13-21	dB	
Common Mode Return Loss (SCC22)	TP4			-2	dB	2
Transition Time, 20 to 80%	TP4	9.5			ps	
Vertical Eye Closure (VEC)	TP4			5.5	dB	
Eye Width at 10 ⁻¹⁵ Probability (EW15)	TP4	0.57			UI	
Eye Height at 10 ⁻¹⁵ Probability (EH15)	TP4	228			mV	

Notes:

1. Vcm is generated by the host. Specification includes effects of ground offset voltage.
2. From 250MHz to 30GHz.

Optical Characteristics (Top = 0 to 70 °C, V_{CC} = 3.135 to 3.465 Volts)

Parameter	Symbol	Min	Typ.	Max	Unit	Notes
Transmitter						
Signaling rate, each lane		26.5625± 100ppm			GBd	PAM4
Optical Wavelength Line0	λ	844		863	nm	
Optical Wavelength Line1	λ	900		918	nm	
RMS Spectral Width	Pm			λ 1: 0.6 λ 2: 0.65	nm	
Average Optical Power per Channel	Pavg	-6.2		+4.0	dBm	
Optical Modulation Amplitude (OMA), each Lane	POMA	-4.2		3	dBm	1
Peak Power, each lane					dBm	
Launch power in OMA minus TDP, each lane		-5.6			dBm	
TDECQ, each lane				4.5	dB	
Extinction Ratio	ER	3.0			dB	
Transmitter Transition Time, each lane (max)				31	ps	
RIN12 OMA				-128	dB/Hz	
Optical Return Loss Tolerance	TOL			12	dB	
Average Launch	Poff			-30	dBm	
Power OFF Transmitter, each Lane						
Encircled Flux		≥ 86% at 19 μ m ≤ 30% at 4.5 μ m				2
Receiver						
Signaling rate, each lane		26.5625± 100ppm			GBd	PAM4
Optical Center Wavelength Line0	λ	844	850	863	nm	
Optical Center Wavelength Line1	λ	900	910	918	nm	
Average Receive Power, each lane		-8.2			dBm	3
Average power at Receiver Input, each lane (overload)				4	dBm	
Receiver Reflectance	RR			-12	dB	

Stressed Receiver Sensitivity in OMA, each lane				-3.5	dBm	4
Receiver Sensitivity (OMA outer), each lane				Max (-6.6, SECQ-8)	dBm	Reference to IEEE 802.3 Clause 150
LOS Assert	LOSA	-30		-14.2	dBm	
LOS Deassert	LOSD			-11.2	dBm	
LOS Hysteresis	LOSH	0.5			dB	
Stressed eye closure (SECQ), each lane	4.5	dB				
OMA of each aggressor, each lane	3	dBm				

Notes:

1. Even if the mTDEC < 0.9 dB, the OMA (min) must exceed this value.
2. If measured into type A1a.2 50um fiber in accordance with IEC 61280-1-4.
3. Average receive power, each lane (min) is informative and not the principal indicator of signal strength. A received power below this value cannot be compliant; however, a value above this does not ensure compliance.
4. Measured with conformance test signal at TP3 as per following

Transceiver Block Diagram

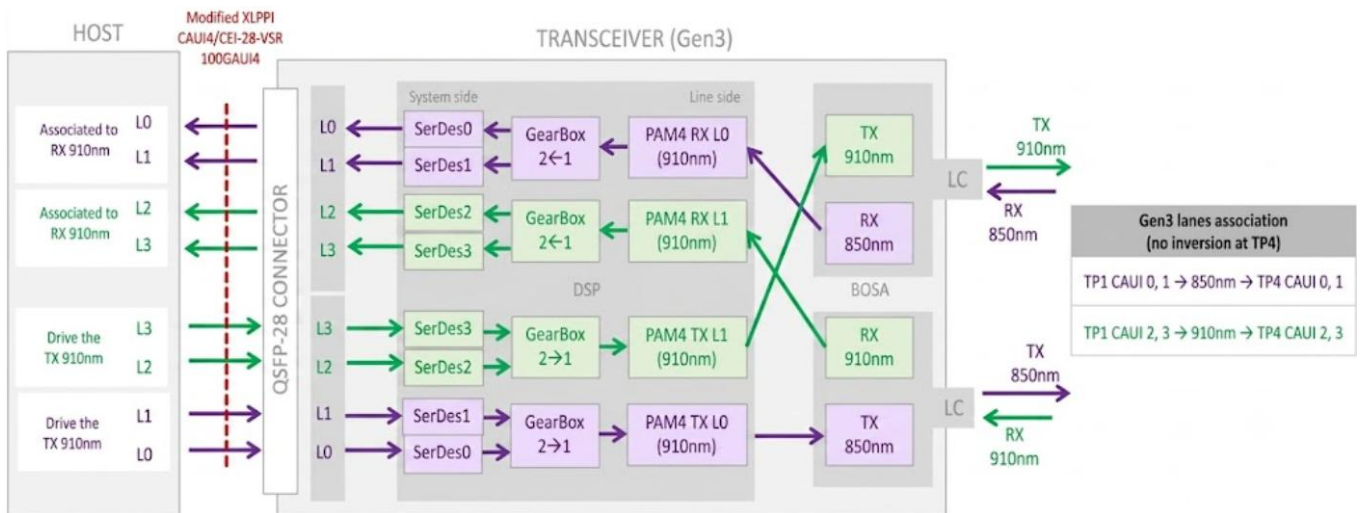

Transceiver Block Diagram

Pin Assignment

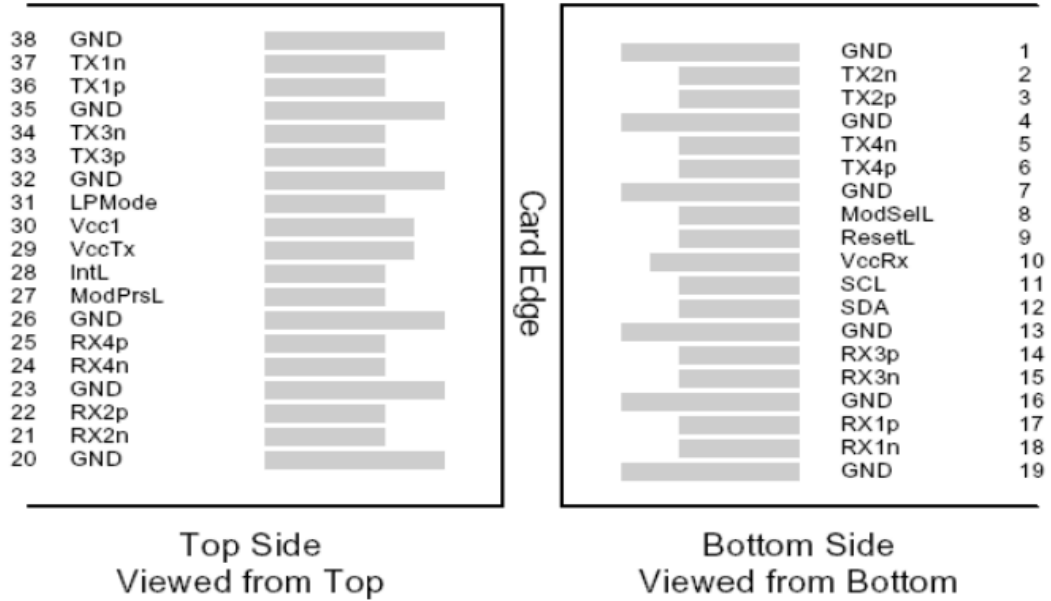

Diagram of Host Board Connector Block Pin Numbers and Name

Pin	Logic	Symbol	Name/Description	Ref.
1		GND	Ground	1
2	CML-I	Tx2n	Transmitter Inverted Data Input	
3	CML-I	Tx2p	Transmitter Non-Inverted Data Input	
4		GND	Ground	1
5	CML-I	Tx4n	Transmitter Inverted Data Input	
6	CML-I	Tx4p	Transmitter Non-Inverted Data Input	
7		GND	Ground	1
8	LVTTL-I	ModSelL	Module Select	
9	LVTTL-I	ResetL	Module Reset	
10		VccRx	+3.3V Power Supply Receiver	2
11	LVC MOS-I/O	SCL	2-Wire Serial Interface Clock	
12	LVC MOS-I/O	SDA	2-Wire Serial Interface Data	
13		GND	Ground	1
14	CML-O	Rx3p	Receiver Non-Inverted Data Output	
15	CML-O	Rx3n	Receiver Inverted Data Output	
16		GND	Ground	1
17	CML-O	Rx1p	Receiver Non-Inverted Data Output	
18	CML-O	Rx1n	Receiver Inverted Data Output	

19		GND	Ground	1
20		GND	Ground	1
21	CML-O	Rx2n	Receiver Inverted Data Output	
22	CML-O	Rx2p	Receiver Non-Inverted Data Output	
23		GND	Ground	1
24	CML-O	Rx4n	Receiver Inverted Data Output	
25	CML-O	Rx4p	Receiver Non-Inverted Data Output	
26		GND	Ground	1
27	LVTTL-O	ModPrsL	Module Present	
28	LVTTL-O	IntL	Interrupt	
29		VccTx	+3.3V Power Supply Transmitter	2
30		Vcc1	+3.3V Power Supply	2
31	LVTTL-I	LPMODE	Low Power Mode	
32		GND	Ground	1
33	CML-I	Tx3p	Transmitter Non-Inverted Data Input	
34	CML-I	Tx3n	Transmitter Inverted Data Input	
35		GND	Ground	1
36	CML-I	Tx1p	Transmitter Non-Inverted Data Input	
37	CML-I	Tx1n	Transmitter Inverted Data Input	
38		GND	Ground	1

Notes:

1. GND is the symbol for single and supply(power) common for QSFP modules, All are common within the QSFP module and all module voltages are referenced to this potential otherwise noted. Connect these directly to the host board signal common ground plane.
2. VccRx, Vcc1 and VccTx are the receiver and transmitter power suppliers and shall be applied concurrently. Recommended host board power supply filtering is shown below. VccRx, Vcc1 and VccTx may be internally connected within the QSFP transceiver module in any combination. The connector pins are each rated for maximum current of 1000mA.

Optical Interface Lanes and Assignment

The following figure shows the orientation of the multi-mode fiber facets of the optical connector. Table 1 provides the lane assignment.

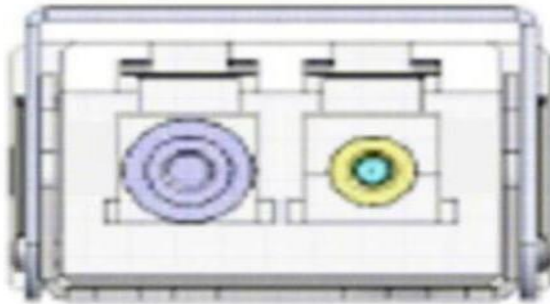

Outside View of the QSFP28 Module LC Receptacle

Recommended Circuit

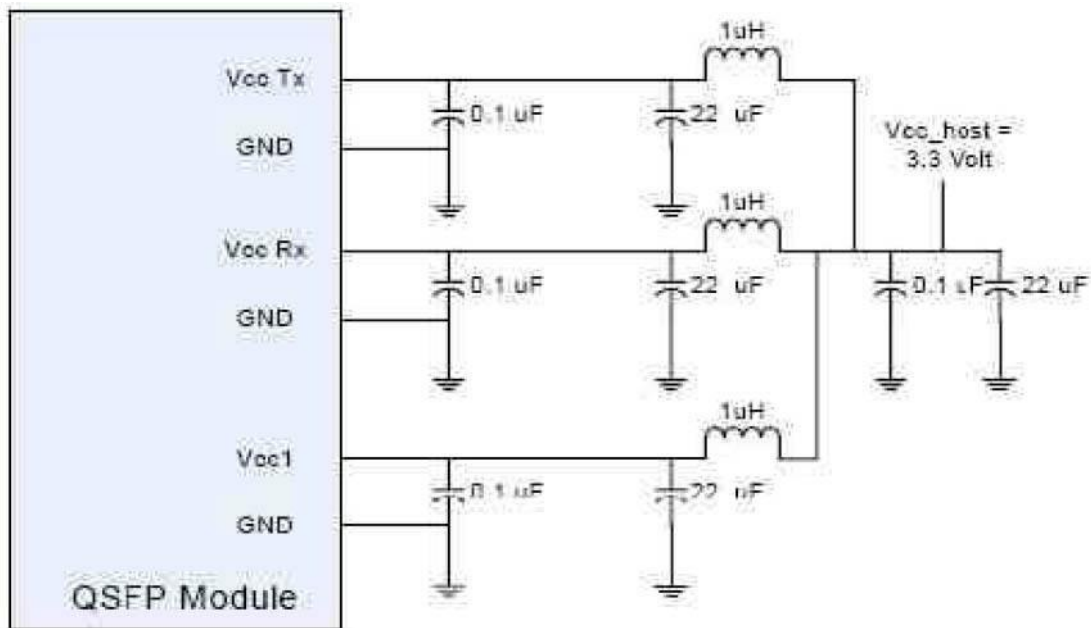

Digital Diagnostic Functions

The following digital diagnostic characteristics are defined over the Recommended Operating Environment unless otherwise specified. It is compliant to SFF-8636.

Parameter	Symbol	Min	Max	Units	Notes
Temperature monitor absolute error	DMI_Temp	-3	3	°C	1
Supply voltage monitor absolute error	DMI_VCC	-0.15	0.15	V	2
Channel RX power monitor absolute error	DMI_RX_Ch	-3	3	dB	
Channel Bias current monitor	DMI_lbias_Ch	-10%	10%	mA	4
Channel TX power monitor absolute error	DMI_TX_Ch	-3	3	dB	1

Notes:

1. Over operating temperature range
2. Over full operating temperature range
3. Ch1 to Ch4

Mechanical Drawing

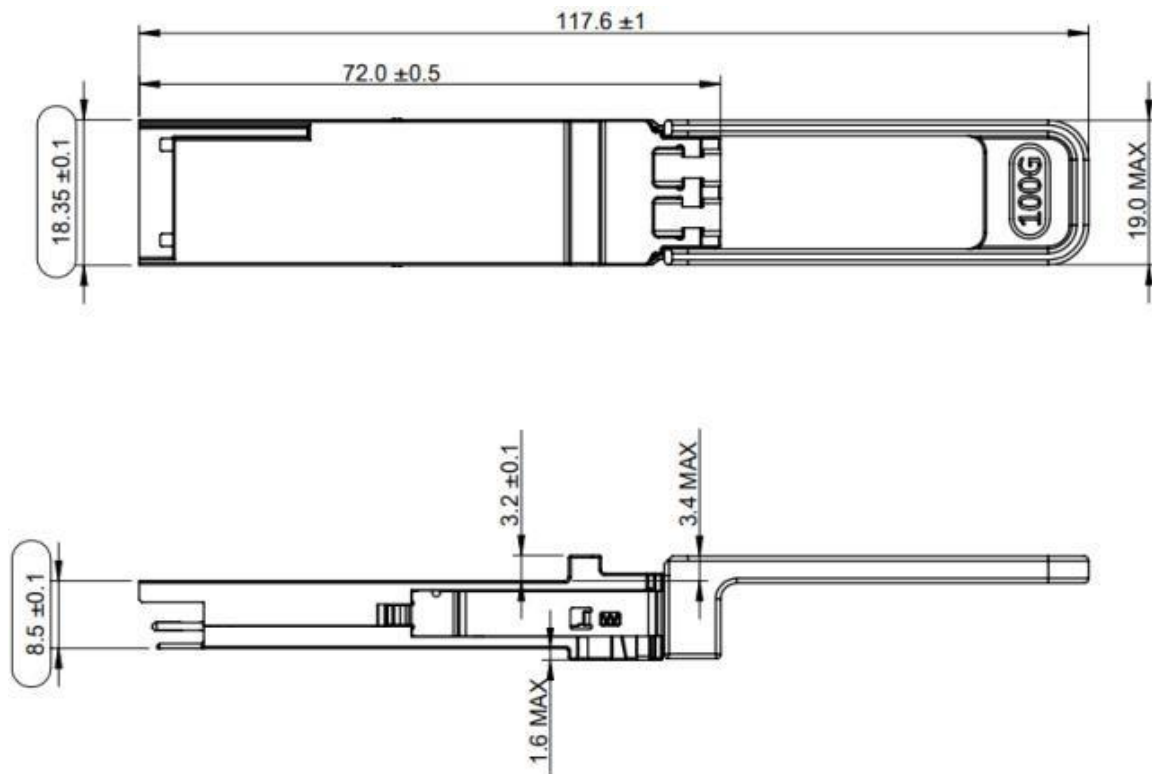

Unit: mm

Ordering Information

Part No	Specification						
	Package	Data rate per Lane	Laser	Reach	Temp.	Application code	Notes
WST-QS28-SRB-MD	QSFP28	53.125 Gbps PAM4	850 nm / 910 nm VCSEL	70 m OM3 100 m OM4 150 m OM5 MMF	0 to 70 °C	100G SR1.2 BIDI	RoHS DDM

Modification History

Revision	Date	Description	Originator	Review	Approved
V1.0	30-Apr-2024	New Issue	Ken Cheng	Joanne Ni	
V1.1	12-Feb-2025	Update operating temperature, photo, and correct typos	Jason Hou	Wayne Liao	Tom Tang



Headquarters

16F-5, No. 75, Sec. 1, Xintai 5th Rd., Xizhi Dist.,
New Taipei City 22101, Taiwan
Tel: +886-2-2698-7208
Fax: +886-2-2698-7210
Email: sales@wavesplitter.com
Website: https://wavesplitter.com/