

## 400G QSFP-DD DR4 500m Transceiver Module P/N: WST-QD4-DR4-C



### Standards:

- IEEE 802.3-2022 400GBASE-DR4 / 400GAUI-8 compliant
- IEEE 802.3-2022 100GBASE-DR / 100GAUI-2 compliant
- QSFP-DD MSA compliant
- CMIS 4.0 management interface

### Description

Wavesplitter's WST-QD4-DR4-C is a 400GBASE-DR4 QSFP-DD optical transceiver designed for 400GE links up to 500 m over single-mode fiber. The module uses an MPO-12 optical connector and supports conversion from 8x 26.5625 GBd PAM4 electrical lanes to 4x 53.125 GBd PAM4 optical lanes. High performance and reliability are achieved through an advanced transmitter and receiver design using cooled 4x EML-LDs and 4x PIN PDs.

### Features:

- Aggregation Mode
  - 400GBASE-DR4 compliant  
4x 53.125GBd PAM4
  - 400GAUI-8 compliant  
8x 26.5625 GBd PAM4
- Breakout Mode
  - 4x 100GBASE-DR compliant  
53.125GBd PAM4
  - 100GAUI-2 compliant  
2x 26.5625 GBd PAM4
- MPO-12 connector with 8° angled end-face
- Power consumption < 8 W
- Operating case temperature 0 to 70 °C
- RoHS compliant

### Applications:

- Data Center 400GE 500 m SMF links
- 400GE to 4x 100GE breakout over 500 m
- Switch/Router interconnections

### Functional Description

The WST-QD4-DR4-C is a fully integrated 425 Gb/s QSFP-DD optical transceiver for single-mode fiber links up to 500 m. It supports the IEEE 802.3 400GBASE-DR4 optical interface and 400GAUI-8 electrical interface. The module converts eight 26.5625 GBd PAM4 electrical lanes into four 53.125 GBd PAM4 optical lanes, and converts the received optical signals back to the host electrical interface through the internal gearbox and DSP.

The transmitter uses four cooled EML-LDs operating in the 1310 nm wavelength range, and the receiver uses four PIN photodiodes with TIAs. The module also supports 4x100G breakout operation with 100GBASE-DR optical lanes and 100GAUI-2 electrical interfaces. Host-side RS-FEC is required to meet the frame loss ratio requirements for 400GE and 4x100GE applications.

### Absolute Maximum Ratings

Stresses in excess of the absolute maximum ratings can cause permanent damage to the device. These are absolute stress ratings only. Functional operation of the device is not implied at these or any other conditions in excess of those given in the operational sections of the data sheet. Exposure to absolute maximum ratings will cause permanent damage and/or adversely affect device reliability.

Parameter	Symbol	Min	Max	Units	Notes
Storage Temperature	TS	-40	85	°C	
Power Supply Voltage	VCC	0	3.6	V	
Optical Receiver Input (each lane)			+5	dBm	

### Recommended Operating Conditions

Parameter	Symbol	Min	Typical	Max	Units	Notes
Operating Case Temperature	TOP	0		70	°C	
Supply Voltage Noise Tolerance	PSNR <sub>mod</sub>			66	mV	10 Hz –10 MHz
Power Supply Voltage	VCC	3.135	3.3	3.465	V	
Power Consumption	P <sub>4</sub>			8	W	
Supply Current	I <sub>cc-4</sub>			2551.8	mA	Steady state
Instantaneous peak current	I <sub>cc_ip_4</sub>			3200	mA	
Sustained peak current	I <sub>cc-sp_4</sub>			2640.3	mA	

### Electrical Characteristics

The following electrical characteristics are defined over the Recommended Operating Environment unless otherwise specified.

Parameter	Min	Typical	Max	Units	Notes
Module output (each lane, at TP4) (Note 1)					
Signaling Rate, each Lane	26.5625 ± 100 ppm			GBd	
AC Common-mode output voltage (RMS)			17.5	mV	
Differential peak-to-peak output voltage			900	mV	
Near-end ESMW (Eye symmetry mask width)	0.265			UI	
Near-end Eye height, differential	70			mV	
Far-end ESMW (Eye symmetry mask width)	0.2			UI	
Far-end Eye height, differential	30			mV	
Far-end pre-cursor ISI ratio	-4.5		2.5	%	
Differential output return loss	Equation (83E-2)			dB	2
Common to differential mode conversion return loss	Equation (83E-3)			dB	2
Differential termination mismatch			10	%	
Transition time (20% to 80%)	9.5			ps	
DC common mode voltage	-350		2850	mV	
Module input (each lane)					
Signaling Rate, each Lane	26.5625 ± 100 ppm			GBd	
Differential pk-pk input voltage tolerance	900			mV	at TP1a
Differential input return loss	Equation (83E-5)			dB	at TP1, 2
Differential to common mode input return loss	Equation (83E-6)			dB	at TP1, 2
Differential termination mismatch	-		10	%	at TP1
ESMW (Eye symmetry mask width)	0.22			UI	at TP1a
Eye width	0.22			UI	at TP1a
Applied pk-pk sinusoidal jitter	Table 120E-6			MHz, UI	at TP1a
Eye height	32			mV	at TP1a
Single-ended input voltage tolerance range	-0.4		3.3	V	at TP1a
DC common mode voltage	-350		2850	mV	at TP1

## Notes:

1. Electrical module output is squelched for loss of optical input signal.
2. IEEE Std 802.3-2022 Section 6.

**Optical Characteristics**

Parameter	Symbol	Min	Typical	Max	Units	Notes
<b>Transmitter</b>						
Wavelength Assignment	$\lambda_c$	1304.5		1317.5	nm	
Channel data rate	$f_{bc}$	106.25			Gbit/s	
Data Rate, each Lane	$f_{sg}$	53.125 $\pm$ 100 ppm			GBd	PSM4
Side-mode suppression ratio	SMSR	30			dB	
Average launch power, each lane		-2.9		4.0	dBm	1
Outer Optical Modulation Amplitude (OMA <sub>outer</sub> ), each lane		-0.8		4.2	dBm	2
Launch power in OMA <sub>outer</sub> minus TDECQ, each lane		-2.2			dBm	
Transmitter and dispersion eye closure for PAM4, each lane	TDECQ			3.4	dB	
Average optical output power of OFF Transmitter, each lane	P <sub>off</sub>			-15	dBm	
Extinction Ratio, each lane	ER	3.5			dB	
RIN <sub>21.4OMA</sub>				-136	dB/Hz	
Optical return loss tolerance				21.4	dB	
Transmitter reflectance				-26	dB	3
<b>Receiver</b>						
Average receive power, each lane		-5.9		4	dBm	4
Receive power (OMA <sub>outer</sub> ), each lane				4.2	dBm	
Receiver reflectance				-26	dB	
Receiver sensitivity (OMA <sub>outer</sub> ), each lane		Max (-3.9, SECQ - 5.3), [Figure 3]			dBm	5, 6
Stressed receiver sensitivity, each lane (OMA <sub>outer</sub> )				-1.9	dBm	5, 7
Conditions of stressed receiver sensitivity test (note 8)						

Stressed eye closure for PAM4, lane under test	SECQ	3.4			dB	
OMA <sub>outer</sub> of each aggressor lane		4.2			dBm	
Receiver Reflectance	RR			-26	dB	
LOS Assert	LOSA	-15		-7.9	dBm	
LOS De-assert	LOSD			-7.4	dBm	
LOS Hysteresis	LOSH	0.5			dB	

Notes:

1. Average launch power, each lane (min) is informative and not the principal indicator of signal strength. A transmitter with launch power below this value cannot be compliant; however, a value above this does not ensure compliance.
2. Even if the TDECQ < 1.4 dB, the OMA<sub>outer</sub> (min) must exceed these values.
3. Transmitter reflectance is defined looking into the transmitter.
4. Average receive power, each lane (min) is informative and not the principal indicator of signal strength. A received power below this value cannot be compliant; however, a value above this does not ensure compliance.
5. For when Pre-FEC BER is  $2.4 \times 10^{-4}$ .
6. Receiver sensitivity (OMA<sub>outer</sub>), each lane (max) is informative and is defined for a transmitter with a value of SECQ up to 3.4 dB.
7. Measured with conformance test signal at TP3 (see IEEE Std 802.3-2022 section 8 clause 124.8.9) for the BER specified in IEEE Std 802.3-2022 section 8 124.1.1.
8. These test conditions are for measuring stressed receiver sensitivity. They are not characteristics of the receiver.

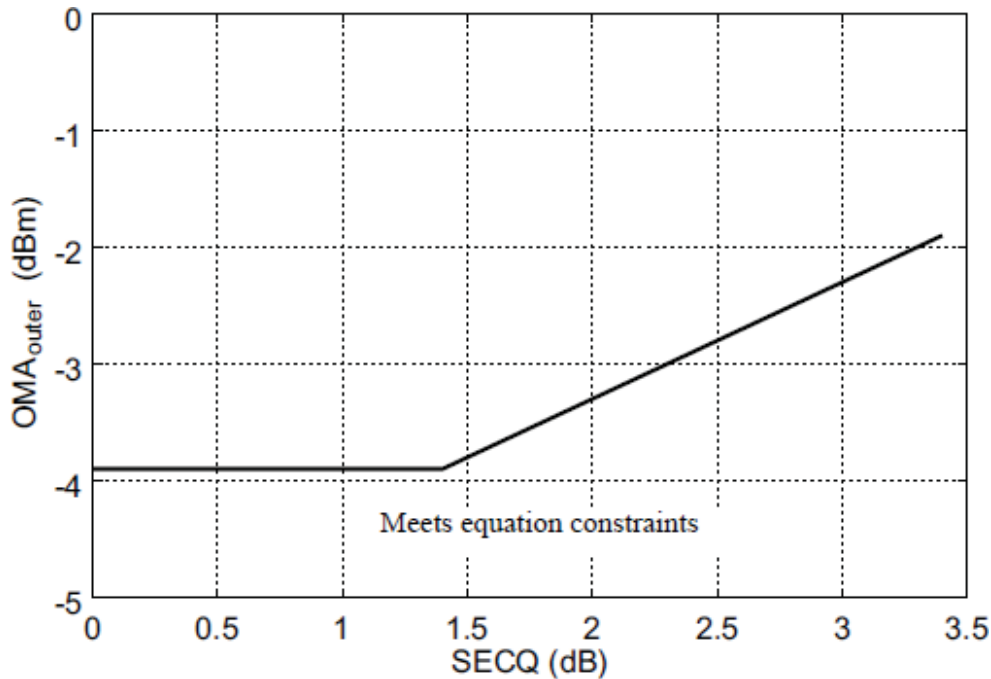

**MEMORY MAP (compliant CMIS 4.0)**

Address	Size (bytes)	Name	Description
128	1	Identifier	Identifier Type of module
129-144	16	Vendor name	Vendor name (ASCII)
145-147	3	Vendor OUI	Vendor IEEE company ID
148-163	16	Vendor PN	Part number provided by vendor (ASCII)
164-165	2	Vendor rev	Revision level for part number provided by vendor (ASCII)
166-181	16	Vendor SN	Vendor Serial Number (ASCII)
182-189	8	Date Code	
190-199	10	CLEI code	Common Language Equipment Identification code
200-201	2	Module power characteristics	
202	1	Cable assembly length	
203	1	Media Connector Type	
204-209	6	Copper Cable Attenuation	
210-211	2	Cable Assembly Lane Information	
212	1	Media Interface Technology	
213-220	8	Reserved	
221	1	Custom	
222	1	Checksum	Includes bytes 128-221
223-255	33	Custom Info NV	

**Digital Diagnostic Functions**

The following digital diagnostic characteristics are defined over the normal operating conditions unless otherwise specified.

Parameter	Symbol	Min	Max	Units	Notes
Temperature monitor absolute error	DMI_Temp	-3	3	°C	Over operating temperature range
Supply voltage monitor absolute error	DMI_VCC	-0.1	0.1	V	Over full operating range
Channel RX power monitor absolute error	DMI_RX_Ch	-2	2	dB	1
Channel Bias current monitor	DMI_Ibias_Ch	-10%	10%	mA	
Channel TX power monitor absolute error	DMI_TX_Ch	-2	2	dB	1

## Notes:

- Due to measurement accuracy of different single mode fibers, there could be an additional +/-1 dB fluctuation, or a +/- 3 dB total accuracy.

**Pin Assignment**

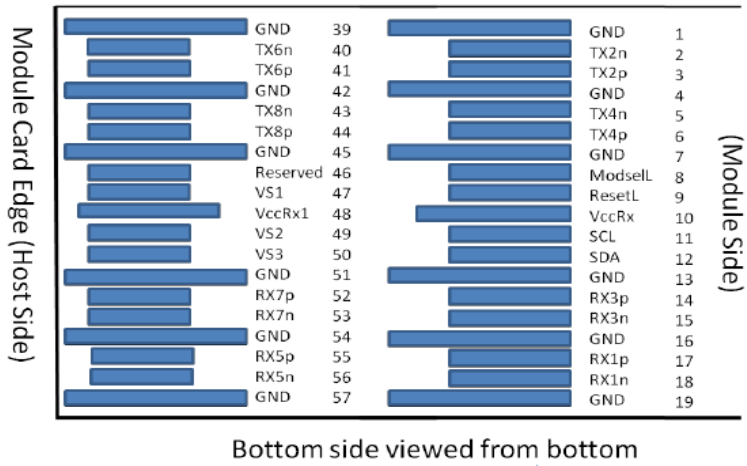
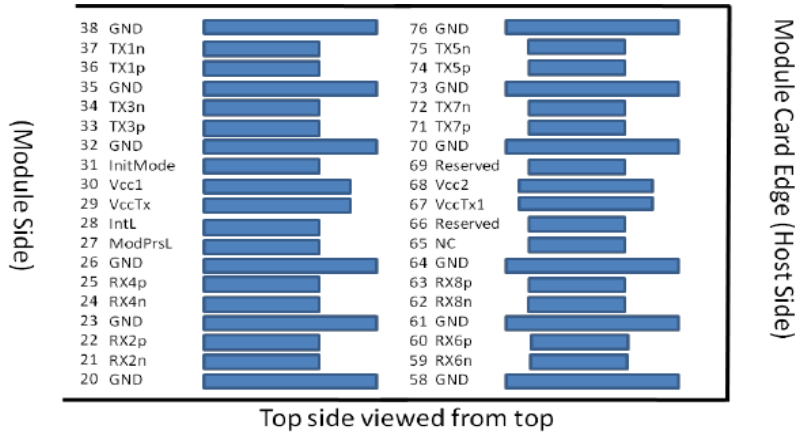

Pin	Logic	Symbol	Description	Plug Sequence	Notes
1		GND	Ground	1B	1
2	CML-I	Tx2n	Transmitter Inverted Data Input	3B	
3	CML-I	Tx2p	Transmitter Non-Inverted Data Input	3B	
4		GND	Ground	1B	1
5	CML-I	Tx4n	Transmitter Inverted Data Input	3B	
6	CML-I	Tx4p	Transmitter Non-Inverted Data Input	3B	
7		GND	Ground	1B	1
8	LVTTL-I	ModSelL	Module Select	3B	

9	LVTTL-I	ResetL	Module Reset	3B	
10		VccRx	+3.3V Power Supply Receiver	2B	2
11	LVC MOS-I/O	SCL	2-wire serial interface clock	3B	
12	LVC MOS-I/O	SDA	2-wire serial interface data	3B	
13		GND	Ground	1B	1
14	CML-O	Rx3p	Receiver Non-Inverted Data Output	3B	
15	CML-O	Rx3n	Receiver Inverted Data Output	3B	1
16		GND	Ground	1B	
17	CML-O	Rx1p	Receiver Non-Inverted Data Output	3B	
18	CML-O	Rx1n	Receiver Inverted Data Output	3B	
19		GND	Ground	1B	1
20		GND	Ground	1B	1
21	CML-O	Rx2n	Receiver Inverted Data Output	3B	
22	CML-O	Rx2p	Receiver Non-Inverted Data Output	3B	
23		GND	Ground	1B	1
24	CML-O	Rx4n	Receiver Inverted Data Output	3B	
25	CML-O	Rx4p	Receiver Non-Inverted Data Output	3B	
26		GND	Ground	1B	1
27	LVTTL-O	ModPrsL	Module Present	3B	
28	LVTTL-O	IntL	Interrupt	3B	
29		VccTx	+3.3V Power supply transmitter	2B	2
30		Vcc1	+3.3V Power supply	2B	2
31	LVTTL-I	InitMode	Initialization mode; In legacy QSFP applications, the InitMode pad is called LPMODE	3B	
32		GND	Ground	1B	1
33	CML-I	Tx3p	Transmitter Non-Inverted Data Input	3B	
34	CML-I	Tx3n	Transmitter Inverted Data Input	3B	
35		GND	Ground	1B	1
36	CML-I	Tx1p	Transmitter Non-Inverted Data Input	3B	
37	CML-I	Tx1n	Transmitter Inverted Data Input	3B	
38		GND	Ground	1B	1
39		GND	Ground	1A	1
40	CML-I	Tx6n	Transmitter Inverted Data Input	3A	
41	CML-I	Tx6p	Transmitter Non-Inverted Data Input	3A	
42		GND	Ground	1A	1
43	CML-I	Tx8n	Transmitter Inverted Data Input	3A	

44	CML-I	Tx8p	Transmitter Non-Inverted Data Input	3A	
45		GND	Ground	1A	1
46		Reserved	For future use	3A	3
47		VS1	Module Vendor Specific 1	3A	3
48		VccRx1	3.3V Power Supply	2A	2
49		VS2	Module Vendor Specific 2	3A	3
50		VS3	Module Vendor Specific 3	3A	3
51		GND	Ground	1A	1
52	CML-O	Rx7p	Receiver Non-Inverted Data Output	3A	
53	CML-O	Rx7n	Receiver Inverted Data Output	3A	
54		GND	Ground	1A	1
55	CML-O	Rx5p	Receiver Non-Inverted Data Output	3A	
56	CML-O	Rx5n	Receiver Inverted Data Output	3A	
57		GND	Ground	1A	1
58		GND	Ground	1A	1
59	CML-O	Rx6n	Receiver Inverted Data Output	3A	
60	CML-O	Rx6p	Receiver Non-Inverted Data Output	3A	
61		GND	Ground	1A	1
62	CML-O	Rx8n	Receiver Inverted Data Output	3A	
63	CML-O	Rx8p	Receiver Non-Inverted Data Output	3A	
64		GND	Ground	1A	1
65		NC	No Connect	3A	3
66		Reserved	For future use	3A	3
67		VccTx1	3.3V Power Supply	2A	2
68		Vcc2	3.3V Power Supply	2A	2
69		Reserved	For Future Use	3A	3
70		GND	Ground	1A	1
71	CML-I	Tx7p	Transmitter Non-Inverted Data Input	3A	
72	CML-I	Tx7n	Transmitter Inverted Data Input	3A	
73		GND	Ground	1A	1
74	CML-I	Tx5p	Transmitter Non-Inverted Data Input	3A	
75	CML-I	Tx5n	Transmitter Inverted Data Input	3A	
76		GND	Ground	1A	1

**Recommended Power Supply Filter**

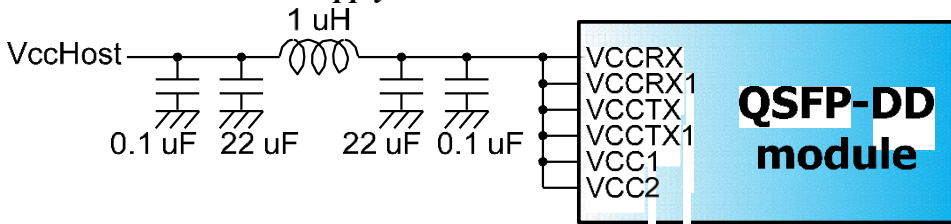

**Recommended Host - Transceiver Interface Block Diagram**

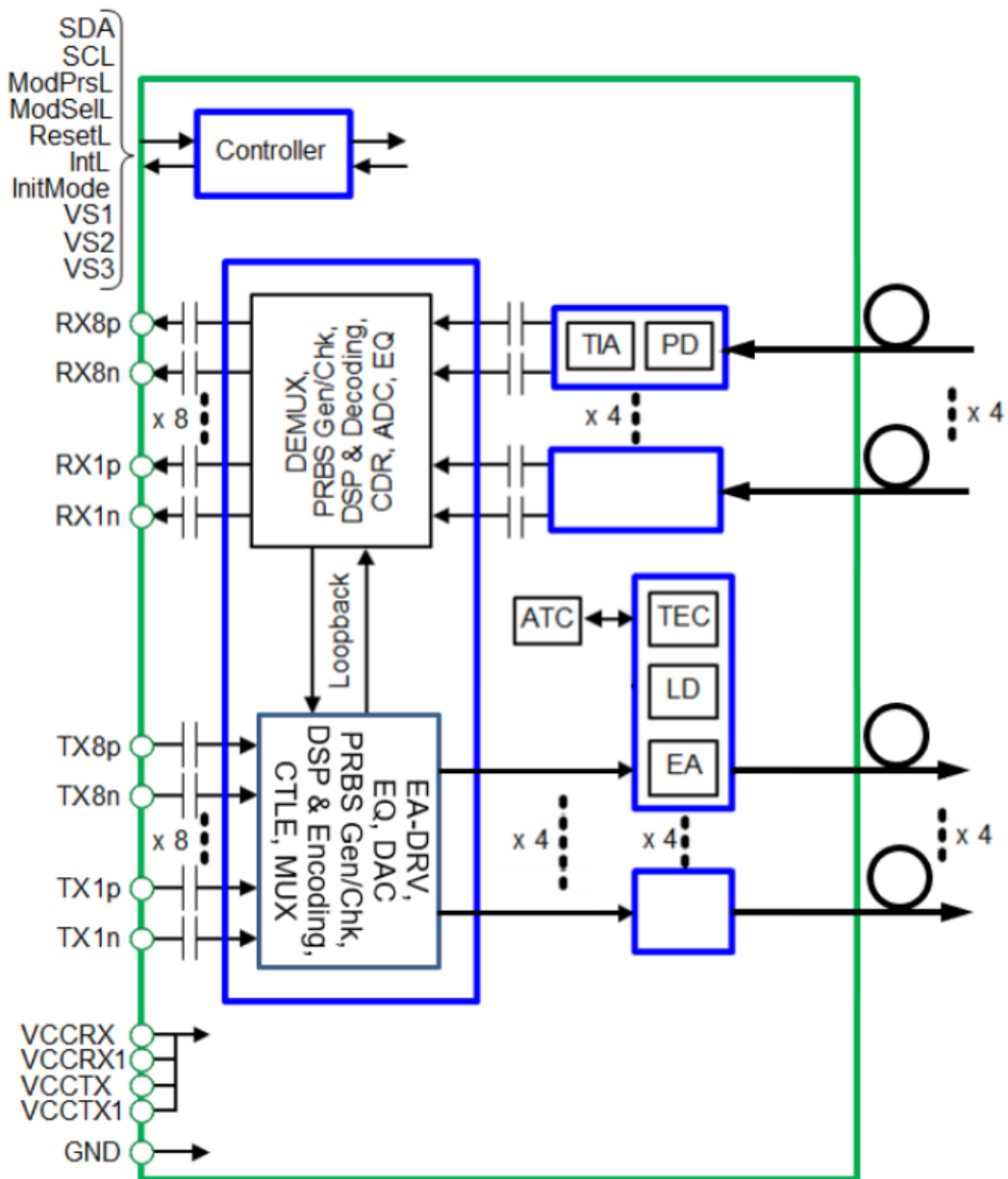

### Mechanical Drawing

Unit: mm

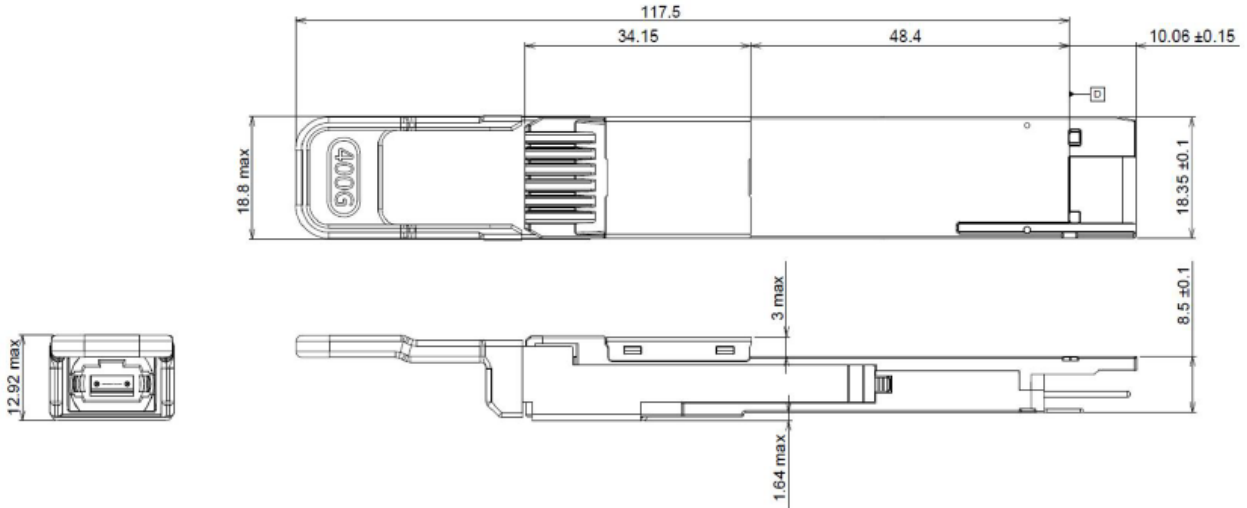

Pull tab color: Yellow

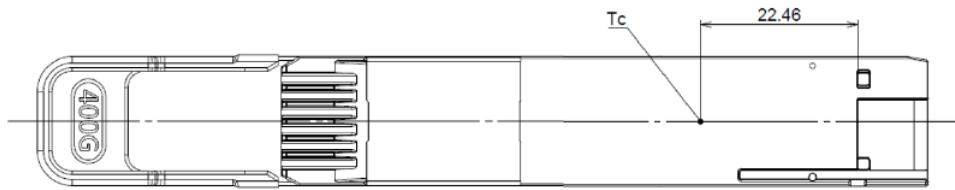

measurement point

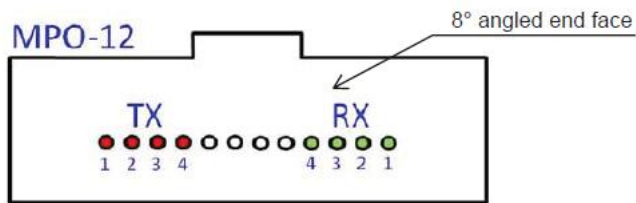

Looking into the connector, transmitter is on the left.

**Ordering Information**

Part No	Specification							
	Package	Data rate	Laser	Detector	Operating temperature	Reach	Other	Application code
WST-QD4-DR4-C	QSFP-DD	106.25Gbps (PAM4) per channel	Cooled 1310 nm EML	PIN	0 ~ 70 °C	500m	DDM RoHS	400G Ethernet

**Modification History**

Revision	Date	Description	Originator	Review	Approved
V1.0	03-Jan-2021	New Issue	ShaoYu Lee	Tom Tang	Wayne Liao
V1.1	14-Oct-2022	Update Pin Assignment	ShaoYu Lee	Tom Tang	Wayne Liao
V1.2	31-Oct-2025	Revise Power Consumption	Amy Lee	Kai-Hsu Cheng	Wayne Liao
V1.3	29-Dec-2025	Update description, functional description, optical characteristics, block diagram, drawing, and ordering information.	Henry Chung	Wayne Liao	Tom Tang

**Headquarters**

6 F., No. 57, Nanxing Rd., Xizhi Dist., New Taipei City  
 221026, Taiwan  
 Tel: +886-2-2698-7208  
 Fax: +886-2-2698-7210  
 Email: sales@wavesplitter.com  
 Website: https://wavesplitter.com