

25GE 30 km 1310 nm Digital Diagnostic SFP28 LC Single-Mode Transceiver (RoHS Compliant)

P/N: WST-S28-ERL-x



Applications:

- 25G Ethernet
- eCPRI Specification V2.0

Features:

- Up to 25.78 Gbps Bi-directional Data Links
- Complaint with SFF-8402 SFP28 MSA
- Support 25GBASE-ER Lite
- eCPRI Specification V2.0
- Built-in dual CDR
- Distance up to 30 km (Non-FEC) / 40km
- 1310nm DFB Transmitter
- SFF-8472 Digital Diagnostic Function
- AC/AC Coupling according to MSA
- Single +3.3 V Power Supply
- RoHS 6/6 Compliant
- 0 to 70 °C Operation: WST-S28-ERL-C
- -10 to 85 °C Operation: WST-S28-ERL-E
- -40 to 85 °C Operation: WST-S28-ERL-I
- Class 1 Laser International Safety Standard IEC-60825 Compliant
- Enhanced EWRAP and OWRAP operational features

Description

WST-S28-ERL-x series single mode transceiver is a small form factor pluggable module for bi-directional serial optical data communications such as 25G Ethernet and eCPRI Specification V2.0. It is with the SFP+ 20-pin connector to allow hot plug capability. Digital diagnostic functions are available via an I²C. This module is designed for single mode fiber and operates at a nominal wavelength of 1310 nm. The transmitter section uses a 1310 nm multiple quantum well DFB laser and is a class 1 laser compliant according to International Safety Standard IEC-60825. The receiver section uses an integrated InGaAs detector preamplifier (IDP) mounted in an optical header and a rate selection clock data recovery (CDR) IC.

LASER SAFETY

This single mode transceiver is a Class 1 laser product. It complies with IEC-60825 and FDA 21 CFR 1040.10 and 1040.11. The transceiver must be operated within the specified temperature and voltage limits. The optical ports of the module shall be terminated with an optical connector or with a dust plug.

Absolute Maximum Ratings

Parameter	Symbol	Min	Max	Units	Notes
Storage Temperature	Tstg	-40	85	°C	
Relative Humidity	RH	5	85	%	Non-condensing
Operating Case Temperature	Topr	0 -10 -40	70 85 85	°C	WST-S28-ERL-C WST-S28-ERL-E WST-S28-ERL-I
Power Supply Voltage	Vcc	-0.5	3.6	V	
Receiver Input Optical Power	Mip		3	dBm	Average power

Recommended Operating Conditions

Parameter	Symbol	Min	Typ	Max	Units / Notes
Power Supply Voltage	Vcc	3.135	3.3	3.465	V
Operating Case Temperature	Topr	0 -10 -40		70 85 85	°C / WST-S28-ERL-C °C / WST-S28-ERL-E °C / WST-S28-ERL-I
Relative Humidity	RH	5		85	% / Non-condensing
Power Supply Current	ICC (TX+RX)		270	340	mA
Data Rate			24.33 / 25.78		Gb/s

Transmitter Optical Specifications (0 °C < Topr < 70 °C, 3.13V < Vcc < 3.47V) Electrical

Parameter	Symbol	Min	Typ	Max	Units	Notes
Average Launch Power	Po, AVG	4		8	dBm	1
Output Center Wavelength	λ_c	1295	1310	1325	nm	
Output Spectrum Width	$\Delta\lambda$	---		1	nm	-20 dB width
Side Mode Suppression Ratio	SMSR	30			dB	
Extinction Ratio	ER	3.5			dB	
Transmitter and Dispersion Penalty	TDP			2.7	dB	
Relative Intensity Noise	RIN			-130	dB/Hz	
Average Launch Power of OFF Transmitter				-30	dBm	

Notes:

- Output power is power coupled into a 9/125 μ m single-mode fiber.

Receiver Optical Specifications ($0^{\circ}\text{C} < T_{opr} < 70^{\circ}\text{C}$, $3.13\text{V} < V_{cc} < 3.47\text{V}$)

Parameter	Symbol	Min	Typ	Max	Units	Notes
Sensitivity, Average	Sen			-13.4	dBm	2
Receiver Overload	P_{MAX}	+2	---		dBm	
LOS – Deasserted	LOS_D	---	---	-14	dBm	Transition: low to high
LOS – Asserted	LOS_A	-24	---	---	dBm	Transition: high to low
Wavelength of Operation	λ_C	1260		1355	nm	
Optical Return Loss	ORL			-27	dB	

Notes:

1. Measured with worst ER; BER < 10^{-6} and PRBS $2^{31}-1$.

Electrical Characteristics

Parameter	Symbol	Min	Typ	Max	Units	Notes
High-Speed Signal (CML) Interface Specification						
Input Data Rate			24.33/25.78		Gb/s	
TX Clock Tolerance		-100		+100	ppm	3
Differential Input Impedance	R_{in}		100		Ω	
Differential Data Input Amplitude		150		1000	mVpp	Internally AC coupled
Output Data Rate		8.5	25.78		Gb/s	
RX Clock Tolerance		-100		+100	ppm	3
Differential Output Impedance	R_{out}		100		Ω	
Differential Data Output Amplitude		350	600	700	mVpp	Internally AC coupled
Low-Speed Signal (LVTTTL) Interface Specification						
Input High Voltage		2.0		$V_{cc}+0.3$	V	
Input Low Voltage		GND		0.8	V	
Output High Voltage		2.4		V_{cc}	V	
Output Low Voltage		GND		0.5	V	

Notes:

1. Clock tolerance for 24.33Gb/s and 25.78Gb/s.

Connection Diagram

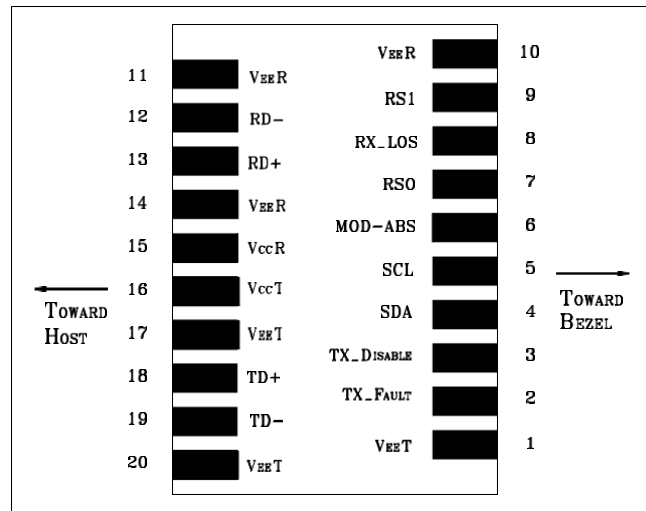

PIN	Signal Name	Description	PIN	Signal Name	Description
1	VEE T	Transmitter Signal Ground	11	VEE R	Receiver Signal Ground
2	TX_Fault	Transmitter Fault Indication. Logic "1" Output = Laser Fault. Logic "0" Output = Normal Operation	12	RD-	Inverse Receiver Data Out
3	TX_Disable	Logic "1" Input (or no connection) = Laser off, Logic "0" = Laser on.	13	RD+	Receiver Data Out
4	SDA	Modulation Definition 2 – Two wires serial ID Interface	14	VEE R	Receiver Signal Ground
5	SCL	Modulation Definition 1 – Two wires serial ID Interface	15	Vcc R	Receiver Power – 3.3V±5%
6	MOD-ABS	Modulation Definition 0 – Ground in Module	16	Vcc T	Transmitter Power – 3.3V±5%
7	RS0	RX Rate Select: This pin has an internal 30k pulldown to ground. A signal on this pin will not affect module performance.	17	VEE T	Transmitter Signal Ground
8	RX_LOS	Loss of Signal Out (OC).	18	TD+	Transmitter Data In
9	RS1	TX Rate Select: This pin has an internal 30k pulldown to ground. A signal on this pin will not affect module performance.	19	TD-	Inverse Transmitter Data In
10	VEE R	Receiver Signal Ground	20	VEE T	Transmitter Signal Ground

Module Definition

Module Definition	PIN 4	PIN 5	PIN 6	Interpretation by Host
4	SDA	SCL	MOD-ABS	Serial module definition protocol

Module Definition 4 specifies a serial definition protocol. For this definition, upon power up, SDA and SCL appear as no connector (NC) and MOD-ABS is TTL LOW. When the host system detects this condition, it activates the serial protocol. The protocol uses the 2-wire serial CMOS E²PROM protocol of the ATMEL AT24C01A/02/04 family of components.

Recommended Circuit Schematic

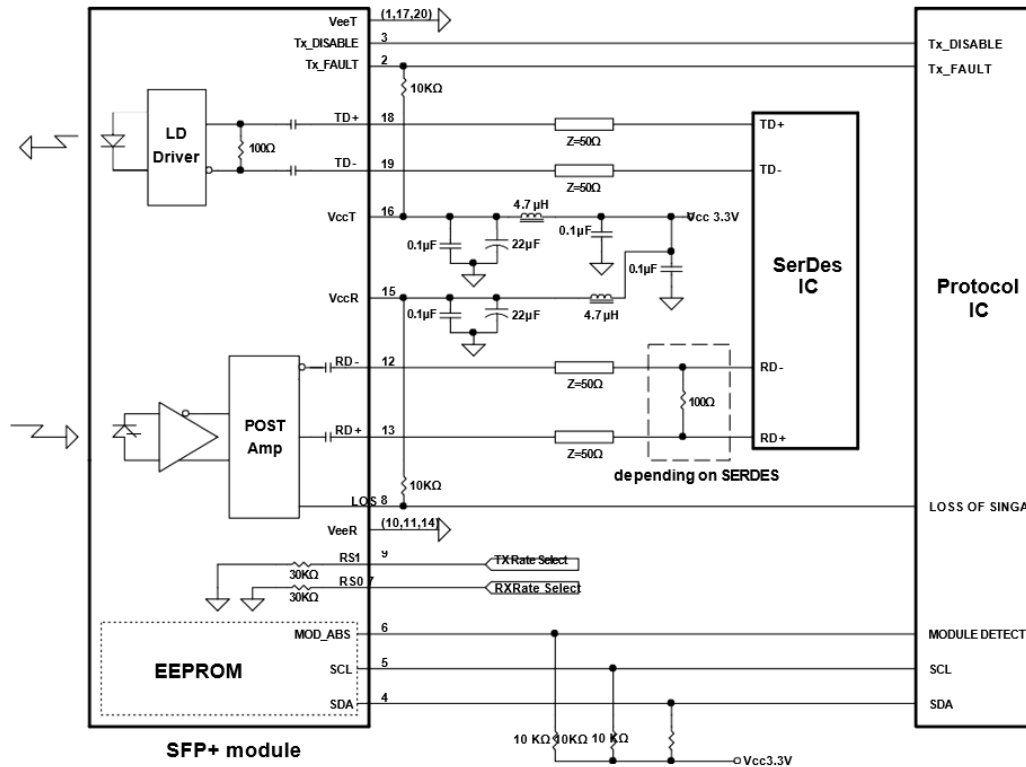

Package Diagram

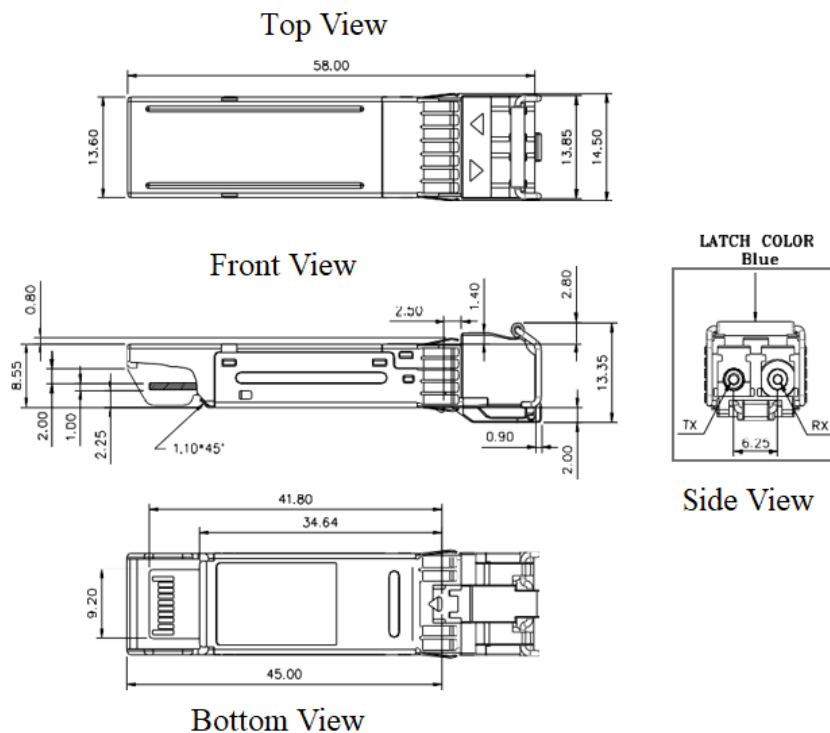

Unit: mm

Note: Specifications subject to change without notice.

WRAP and BYPASS CDR operation functions - Soft Control (Address A2h, Byte 111).

To assist with local host or remote diagnostic and optimization sequences, electrical and optical wrap functions can be enabled. Optical wrap (OWRAP) takes the received optical signal through CDRs and retransmits it optically out. Electrical wrap (EWRAP) takes the received electrical signal through CDRs and retransmits it electrically out. Optional forward functions can be transmitted outbound the wrapped information via I²c control.

Byte	Bit	Name	Description
	4-7	Reserved	Reserved.
	3	OWRAP Forward Enable Bit	When set in combination with OWRAP Enable, OWRAP Forward routes incoming SFP+ Rx optical data to both the Tx optical output and the Rx electrical output. Enabling sets bit 2 and clears all other bits in byte 111.
	2	OWRAP Enable Bit	When set, OWRAP routes incoming SFP+ Rx optical data to the Tx optical output. Enabling clears all other bits in byte 111.
	1	EWRAP Forward Enable Bit	When set in combination with EWRAP Enable, EWRAP Forward routes incoming SFP+ Tx electrical data to both Rx electrical output and Tx optical output. Enabling sets bit 0 and clears all other bits in byte 111.
	0	EWRAP Enable Bit	When set, EWRAP Enable routes incoming SFP+ Tx electrical data to the Rx electrical output. Enabling clears all other bits in byte 111.

OWRAP FORWARD enable MODE (I²C Controlled)

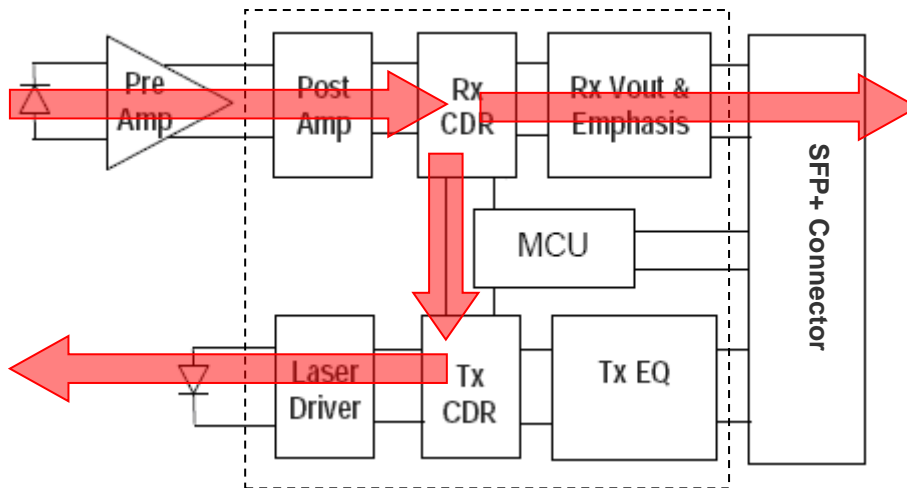

OWRAP enable MODE (I²C Controlled)

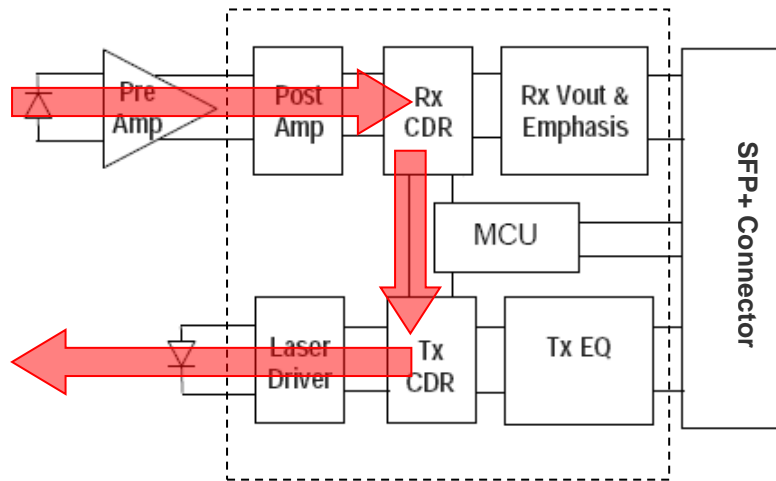

Ewrap forward enable MODE (I²C Controlled)

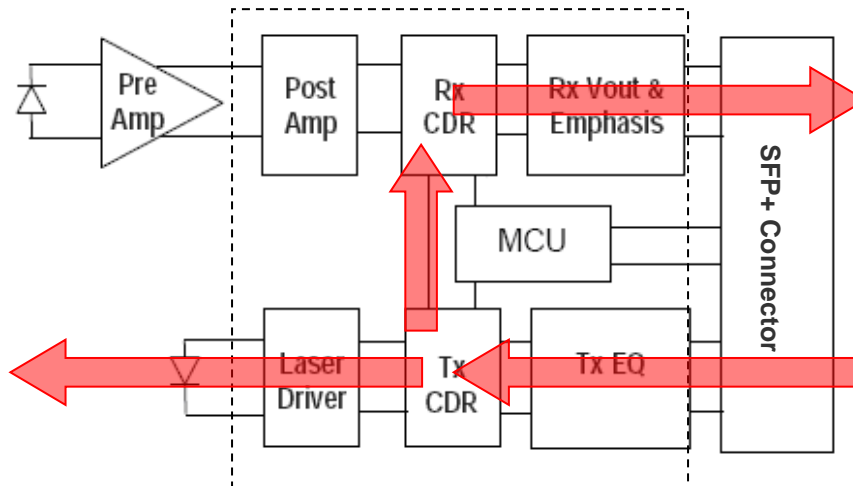

Ewrap enable MODE (I²C Controlled)

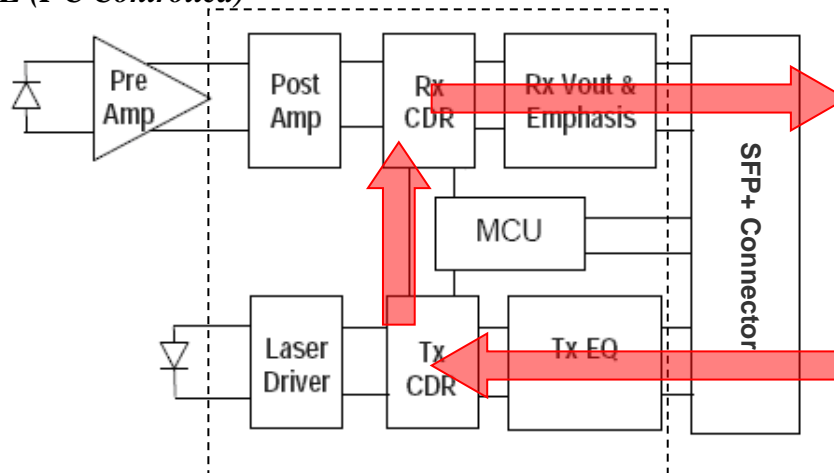

EEPROM Series ID Memory Contents (Address A0h)

Addr.	Hex	ASCII	Note	Addr.	Hex	ASCII	Note	Addr.	Hex	ASCII	Note	Addr.	Hex	ASCII	Note				
0	03		SFP+	32	20			64	18		Power Level 1, w/ CDR, Uncooled Tx, Txdis, Txfault, LOS	96	00		Vendor specific EEPROM				
1	04			33	20			65	1A				97	00					
2	07		LC	34	20			66	68			25.78Gbps	98	00					
3	00			35	20			67	00				99	00					
4	00			36	00		NA	68			Serial number: each piece with different serial number	100	00						
5	00			37	00		Vendor IEEE OUI	69					101	00					
6	00			38	0F				70					102		00			
7	00			39	0E				71					103		00			
8	00			40	57	W	Part Number	72					104	00					
9	00			41	53	S			73					105		00			
10	00			42	54	T			74					106		00			
11	06		64B/66B	43	2D	-			75					107		00			
12	FF		> 25Gbps	44	53	S			76					108		00			
13	00			45	32	2			77					109		00			
14	1E		30km	46	38	8			78					110		00			
15	FF		> 25.4km	47	2B	+			79					111		00			
16	00			48	45	E			80					112		00			
17	00			49	52	R			81					113		00			
18	00			50	4C	L			82					114		00			
19	00			51	2D	-			83				115	00					
20	57	W	Vendor name	52	43	C		Revision, depended on version	84		Y	Date Code	116	00					
21	41	A			53	20					85			Y			117	00	
22	56	V			54	20					86			M			118	00	
23	45	E			55	20				87			M			119	00		
24	53	S			56	30	0			88			D			120	00		
25	50	P			57	31	1		89		D			121		00			
26	4C	L			58	20			90	20				122		00			
27	49	I			59	20			91	20				123		00			
28	54	T			60	05		1310 nm	92	68			Monitoring	124		00			
29	54	T			61	1E				93	F0			Soft Control and Monitoring		125	00		
30	45	E			62	00		Reserved	94	08		SFF-8472 V12.0	126	00					
31	52	R			63			Checksum 0-62	95			Checksum 64-94	127	00					

EEPROM Series ID Memory Contents (Address A2h)

Addr.	Hex	Note	Addr.	Hex	Note	Addr.	Hex	Note	Addr.	Hex	Note
0	4B	Temp. High Alarm (75 °C)	32	4D	Rx Power High Alarm (3dBm)	64	00	For External Cal.	96		Real Time Temp. MSB
1	00		33	F1		65	00	For External Cal.	97		Real Time Temp. LSB
2	FB	Temp. Low Alarm (-5 °C)	34	01	Rx Power Low Alarm (-15.4dBm)	66	00	For External Cal.	98		Real Time Vcc MSB
3	00		35	20		67	00	For External Cal.	99		Real Time Vcc LSB
4	49	Temp. High Warming (73 °C)	36	3D	Rx Power High Warming (2dBm)	68	3F	For External Cal.	100		Real Time Tx Bias MSB
5	00		37	E9		69	80	For External Cal.	101		Real Time Tx Bias LSB
6	00	Temp. Low Warming (0 °C)	38	01	Rx Power Low Warming(-13.4dB m)	70	00	For External Cal.	102		Real Time Tx Pwr MSB
7	00		39	C9		71	00	For External Cal.	103		Real Time Tx Pwr LSB
8	8C	Voltage High Alarm (3.6V)	40	00	Reserved	72	00	For External Cal.	104		Real Time Rx Pwr MSB
9	A0		41	00	Reserved	73	00	For External Cal.	105		Real Time Rx Pwr LSB
10	75	Voltage Low Alarm (3.0V)	42	00	Reserved	74	00	For External Cal.	106		Reserved
11	30		43	00	Reserved	75	00	For External Cal.	107		Reserved
12	88	Voltage High Warming (3.5V)	44	00	Reserved	76	01	For External Cal.	108		Reserved
13	B8		45	00	Reserved	77	00	For External Cal.	109		Reserved
14	79	Voltage Low Warming (3.1V)	46	00	Reserved	78	00	For External Cal.	110		Tx Dis, Tx Fault, Rx Los
15	18		47	00	Reserved	79	00	For External Cal.	111		OWRAP, EWRAP
16	AF	Tx Bias High Alarm (90mA)	48	00	Reserved	80	01	For External Cal.	112		Alarm Flag
17	C8		49	00	Reserved	81	00	For External Cal.	113		Alarm Flag/Reserved
18	03	Tx Bias Low Alarm (2mA)	50	00	Reserved	82	00	For External Cal.	114		Reserved
19	E8		51	00	Reserved	83	00	For External Cal.	115		Reserved
20	9C	Tx Bias High Warming (80mA)	52	00	Reserved	84	01	For External Cal.	116		Warming Flag
21	40		53	00	Reserved	85	00	For External Cal.	117		Warming Flag/Reserved
22	07	Tx Bias Low Warming (4mA)	54	00	Reserved	86	00	For External Cal.	118		RS1 Select
23	D0		55	00	Reserved	87	00	For External Cal.	119		Reserved
24	FF	Tx Power High	56	00	For External Cal.	88	01	For External Cal.	120		Vendor Specific
25	FE	Alarm (8.16dBm)	57	00	For External Cal.	89	00	For External Cal.	121		
26	4D	Tx Power Low	58	00	For External Cal.	90	00	For External Cal.	122		
27	F1	Alarm (3dBm)	59	00	For External Cal.	91	00	For External Cal.	123		
28	F6	Tx Power High	60	00	For External Cal.	92	00	For External Cal.	124		
29	78	Warming (8dBm)	61	00	For External Cal.	93	00	For External Cal.	125		
30	62	Tx Power Low	62	00	For External Cal.	94	00	For External Cal.	126		
31	1F	Warming (4dBm)	63	00	For External Cal.	95		Check Sum	127		

Note: Address 128 – 247: customer R/W EEPROM. Address 248 – 255: Vendor Specific.

Ordering Information

P/No.	Specification						
	Bit Rate (Gb/s)	25GBASE	Distance (km)	Wavelength (nm)	Package	Case Temp (°C)	RoHS Compliant
WST-S28-ERL-C	Up to 25.78	ER Lite	30*	1310 DFB	SFP28 with DMI	0 to 70	Yes
WST-S28-ERL-E	Up to 25.78	ER Lite	30*	1310 DFB	SFP28 with DMI	-10 to 85	Yes
WST-S28-ERL-I	Up to 25.78	ER Lite	30*	1310 DFB	SFP28 with DMI	-40 to 85	Yes

Note: *Non-FEC

Modification History

Revision	Date	Description	Originator	Review	Approved
V1.0	26-Nov-2018	New Issue	Ivy Chen	Wayne Liao	Wayne Liao
V1.1	11-Jan-2019	Update picture	Ivy Chen	Wayne Liao	Wayne Liao
V1.2	26-Mar-2020	Update Feature	Ivy Chen	Wayne Liao	Wayne Liao



Taipei Headquarters
16F-5, No. 75, Sec. 1,
Xintai 5th Rd., Xizhi Dist.,
New Taipei City 22101,
Taiwan
Tel: +886-2-2698-7208
Fax: +886-2-2698-7210

U.S. Branch
2080 Rancho Higuera Ct.
Fremont, CA 94539,
USA
Tel: 510-651-7800
Fax: 510-651-7822

ShenZhen Branch
610#, 6F, No.204 Building,
2nd Industrial zone
Nanyou, Nanshan district,
Shenzhen, Guangdong
China 518054
Tel: +86-755-86265980
Fax: +86-755-26642741