

Data Sheet

40G QSFP+ Active Optical Cable

P/N: WS-QSFP+AOCxCxxx



Features:

- Support 40GBASE-SR4/QDR application
- Compliant to QSFP+ Electrical MSA SFF-8436
- Multi rate of up to 10.3125Gbps
- +3.3V single power supply
- Low power consumption
- Operating case temp Commercial: 0°C to +70 °C
- UL certification cables (optional)
- RoHS compliant

Applications:

- 40GBASE-SR4 at 10.3125Gbps per lane
- InfiniBand QDR
- Other optical links

Absolute Maximum Ratings

Parameter	Symbol	Min.	Typical	Max.	Unit	Notes
Supply Voltage	V _{CC3}	-0.5	-	+3.6	V	
Storage Temperature	T _s	-10	-	+70	°C	
Operating Humidity	RH	+5	-	+85	%	1

Note :

1 No condensation

Recommended Operating Conditions

Parameter	Symbol	Min.	Typical	Max.	Unit	Notes
Operating Case Temperature	T _c	0	-	+70	°C	
Power Supply Voltage	V _{cc}	3.14	3.3	3.47	V	
Power Dissipation	P _d	-	-	1.5	W	1
Bit Rate	BR	1.25	10.3125	-	Gbps	

Note:

1 Per terminal

Electrical Characteristics

Parameter	Symbol	Min.	Typ.	Max.	Units	Notes
ModSelL	Module Select	V _{OL}	0	-	0.8	V
	Module Unselect	V _{OH}	2.5	-	V _{CC}	V
LPMode	Low Power Mode	V _{IL}	0	-	0.8	V
	Normal Operation	V _{IH}	2.5	-	V _{CC} +0.3	V
ResetL	Reset	V _{IL}	0	-	0.8	V
	Normal Operation	V _{IH}	2.5	-	V _{CC} +0.3	V
ModPrsL	Normal Operation	V _{OL}	0	-	0.4	V
IntL	Interrupt	V _{OL}	0	-	0.4	V
	Normal Operation	V _{OH}	2.4	-	V _{CC}	V
Electrical transmitter Characteristics						
Differential Data Input Swing	V _{out}	200	-	1600	mV	
Output Differential Impedance	Z _D	90	100	110	Ω	
Electrical Receiver Characteristics						
Differential Data Output Swing	V _{in,P-P}	350	-	800	mV _{PP}	
Bit Error Rate	BER			E-12		1
Input Differential Impedance	Z _{IN}	90	100	110	Ω	

Note:

1 PRBS2³¹-1@10.3125Gbps

Pin arrangement

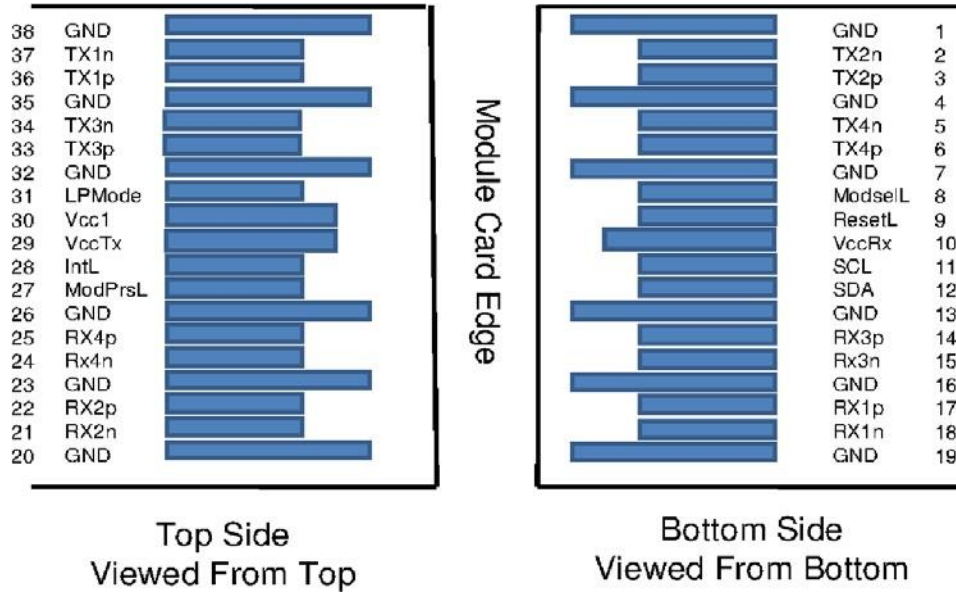

Pin out of Connector Block on Host Board

Pin	Symbol	Name/Description	Notes
1	GND	Ground	1
2	Tx2n	Transmitter Inverted Data Input	
3	Tx2p	Transmitter Non-Inverted Data Input	
4	GND	Ground	1
5	Tx4n	Transmitter Inverted Data Input	
6	Tx4p	Transmitter Non-Inverted Data Input	
7	GND	Ground	1
8	ModSelL	Module Select	
9	ResetL	Module Reset	
10	Vcc Rx	+3.3V Power Supply Receiver	
11	SCL	2-wire serial interface clock	
12	SDA	2-wire serial interface data	
13	GND	Ground	1
14	Rx3p	Receiver Non-Inverted Data Output	
15	Rx3n	Receiver Inverted Data Output	
16	GND	Ground	1

17	Rx1p	Receiver Non-Inverted Data Output	
18	Rx1n	Receiver Inverted Data Output	
19	GND	Ground	1
20	GND	Ground	1
21	Rx2n	Receiver Inverted Data Output	
22	Rx2p	Receiver Non-Inverted Data Output	
23	GND	Ground	1
24	Rx4n	Receiver Inverted Data Output	
25	Rx4p	Receiver Non-Inverted Data Output	
26	GND	Ground	1

Note:

1. Circuit ground is internally isolated from chassis ground.

Recommended Host - Transceiver Interface Block Diagram

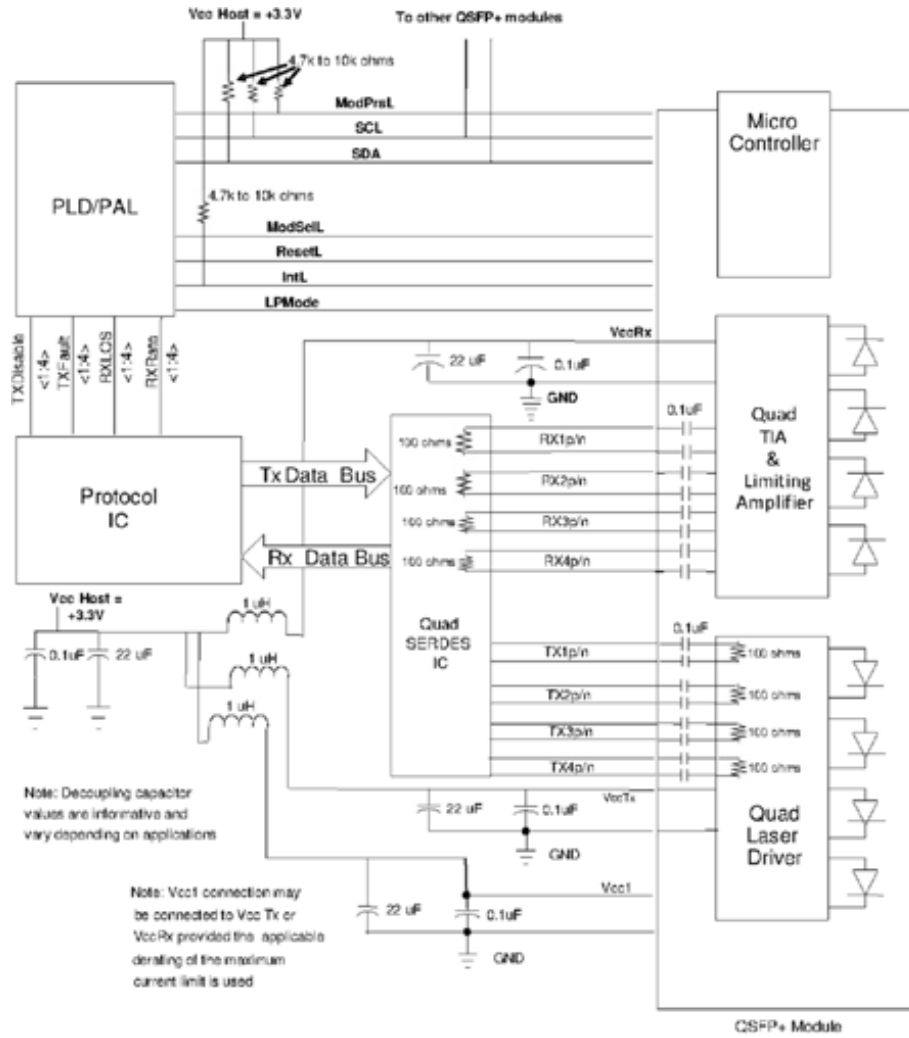

Recommended Typical Application Circuit

Memory map

2-Wire Serial Address 1010000x	
Lower Page 00h	
0	Identifier
1- 2	Status
3- 21	Interrupt Flags
22- 33	Free Side Device Monitors
34- 81	Channel Monitors
82- 85	Reserved
86- 98	Control
99	Reserved
100-104	Hardware Interrupt Pin Masks
105-106	Vendor Specific
107	Reserved
108-110	Free Side Device Properties
111-112	Assigned for use by PCI Express
113	Free Side Device Properties
114-118	Reserved
119-122	Password Change Entry Area (Optional)
123-126	Password Entry Area (Optional)
127	Page Select Byte

Upper Page 00h	Optional Page 01h	Optional Page 02h	Optional Page 03h
128 Identifier	128 CC_APPS	128-255 User EEPROM Data	128-175 Free Side Device Thresholds
129-191 Base ID Fields	129 AST Table Length (TL)		176-223 Channel Thresholds
	130-131 Application Code Entry 0		
	132-133 Application Code Entry 1		
	134-253 other entries		
192-223 Extended ID		224 Tx EQ & Rx Emphasis Magnitude ID	
224-255 Vendor Specific ID		225 RX output amplitude indicators	
		226-241 Channel Controls	
		242-251 Channel Monitor Masks	
	254-255 Application Code Entry TL		252-255 Reserved

Mechanical Drawing

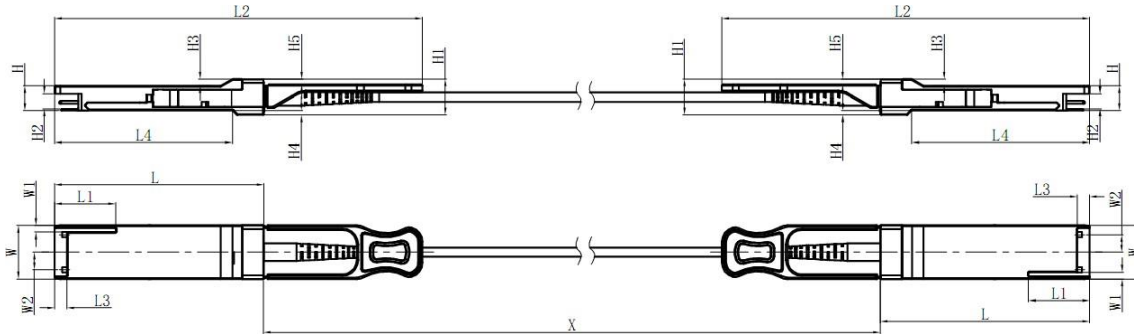

Unit: mm

	L	L1	L2	L3	L4	W	W1	W2	H	H1	H2	H3	H4	H5	H6
Max	72.2	-	128	4.35	61.4	18.45	-	6.2	8.6	12.4	5.35	2.5	1.6	2.0	-
Type	72.0	-	-	4.20	61.2	18.35	-	-	8.5	12.2	5.2	2.3	1.5	1.8	6.55
Min	68.8	16.5	124	4.05	61.0	18.25	2.2	5.8	8.4	12.0	5.05	2.1	1.3	1.6	-

Cable Length (Unit: m)	Tolerant (Unit: cm)
< 1.0	+5/-0
1.0~4.5	+15/-0
5.0~14.5	+30/-0
≥15.0	+2%/-0

Ordering Information

Part No	Specification							
	Package	Data rate	Laser	Fiber	Cable Type	Cable Length	Temp.	Application
WS-QSFP+AOCxC033	QSFP+	41.25Gbps	850nm	OM3	Round LSZH, OFNP, or OFNR	3m	0~70°C	40GBASE InfiniBand QDR
WS-QSFP+AOCxC053	QSFP+	41.25Gbps	850nm	OM3	Round LSZH, OFNP, or OFNR	5m	0~70°C	40GBASE InfiniBand QDR
WS-QSFP+AOCxC073	QSFP+	41.25Gbps	850nm	OM3	Round LSZH, OFNP, or OFNR	7m	0~70°C	40GBASE InfiniBand QDR
WS-QSFP+AOCxC103	QSFP+	41.25Gbps	850nm	OM3	Round LSZH, OFNP, or OFNR	10m	0~70°C	40GBASE InfiniBand QDR
WS-QSFP+AOCxC153	QSFP+	41.25Gbps	850nm	OM3	Round LSZH, OFNP, or OFNR	15m	0~70°C	40GBASE InfiniBand QDR
WS-QSFP+AOCxC203	QSFP+	41.25Gbps	850nm	OM3	Round LSZH, OFNP, or OFNR	20m	0~70°C	40GBASE InfiniBand QDR
WS-QSFP+AOCxC704	QSFP+	41.25Gbps	850nm	OM4	Round LSZH, OFNP, or OFNR	70m	0~70°C	40GBASE InfiniBand QDR
WS-QSFP+AOCxCyym	QSFP+	41.25Gbps	850nm	OMm	Round LSZH, OFNP, or OFNR	yy	0~70°C	40GBASE InfiniBand QDR

Note: **WS-QSFP+AOCxCyym**:

Cable type: x= L for LSZH, P for OFNP, and R for OFNR

Length: yy

Fiber: m= 2 for OM2 ($\leq 30m$), 3 for OM3 ($\leq 70m$), and 4 for OM4 ($\leq 100m$)

Variant Length and Cable Types can be customized. Please contact our sales for detail information.

Modification History

Revision	Date	Description	Originator	Review	Approved
V1.0	06-Aug-2020	New Issue	Elma Yueh	Wayne Liao	Wayne Liao
V1.1	18-Jun-2021	Update Ordering Information	ShaoYu Lee	Wayne Liao	Wayne Liao



Taipei Headquarters
16F-5, No. 75, Sec. 1,
Xintai 5th Rd., Xizhi
Dist., New Taipei City
22101, Taiwan
Tel: +886-2-2698-7208
Fax: +886-2-2698-7210

U.S. Branch
2080 Rancho Higuera Ct.
Fremont, CA 94539,
USA
Tel: 510-651-7800
Fax: 510-651-7822

ShenZhen Branch
610#, 6F, No.204
Building, 2nd Industrial
zone Nanyou, Nanshan
district, Shenzhen,
Guangdong China
518054
Tel: +86-755-86265980